

CO-OP ASSEMBLY INSTRUCTIONS – MODEL 6513-65TS

Hardware Included:

- [A] 1/4-20 x 1" hex bolt (7)
- [B] 1/4-20 x .75" decorative screw (4)
- [C] 5/16-18 x 1.5" hex bolt (1)
- [D] 5/16-18 x 2" hex bolt (4)
- [E] 2" wood screws (6)
- [F] 3/8 x 5" anchor bolts (4)

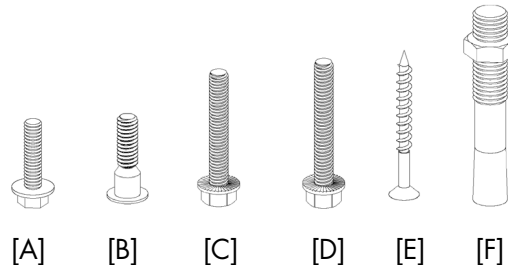

IMPORTANT – HARDWARE IS SPECIFIC FOR THE ASSEMBLY OF EACH COMPONENT. MAKE SURE THE CORRECT ITEMS ARE USED AS DIRECTED AND IDENTIFIED BELOW.

Step 1: Remove the back cushions on the seating units by gently applying upward force to release it from the z-brackets that are holding it in place (Figure A).

Step 2: With the back removed, slightly tilt the back of the seat cushion upwards, approximately 45-degrees, and pull until it comes out (Figure B).

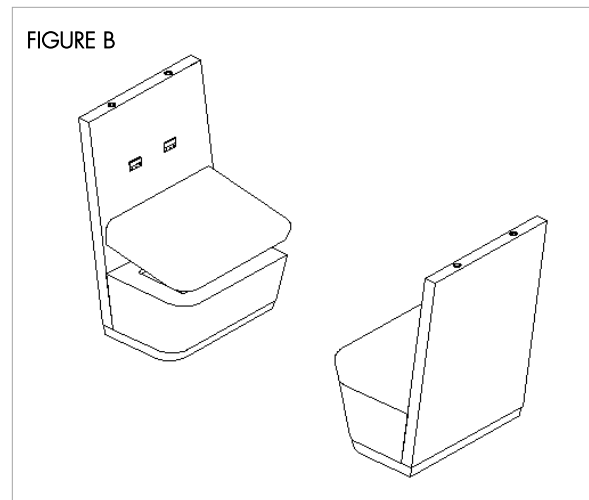
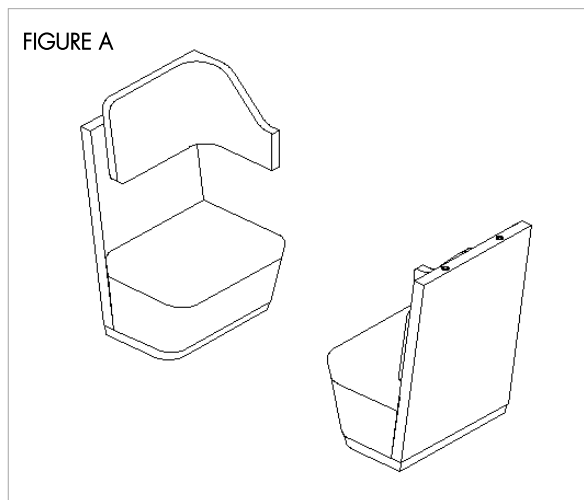

continued next page

Step 3: Once back and seat cushions are removed, face the two seating units approximately 42.75" away from each other (measurement is taken from the bottom front of both plinth bases). Align the wing brackets on the seating units with the wing brackets on the back panel. Secure the seats to the back panel by using (4) 5/16-18 x 2" hex bolts [D], two per seat from the inside of the seat. The bolts go into pre-inserted t-nuts in the back panel (Figure C).

Step 4: Align the small accent tier attachment pins to the top of the seating unit bushings and push down to secure. Next, insert the long accent tier by repeating the same process while at the same time, aligning it to the small accent tiers with the four wing brackets, one per side (Figure D).

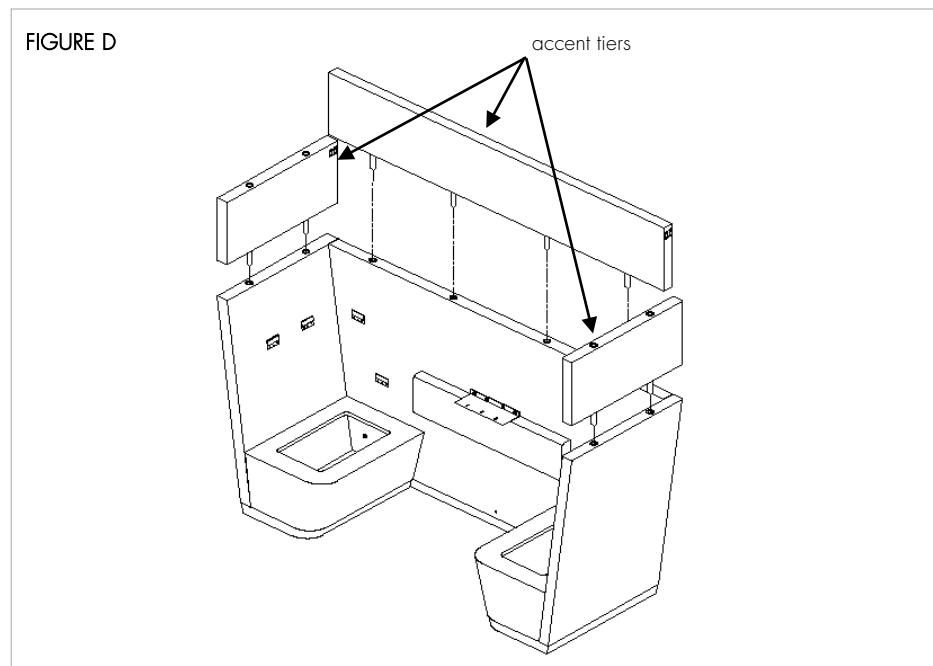
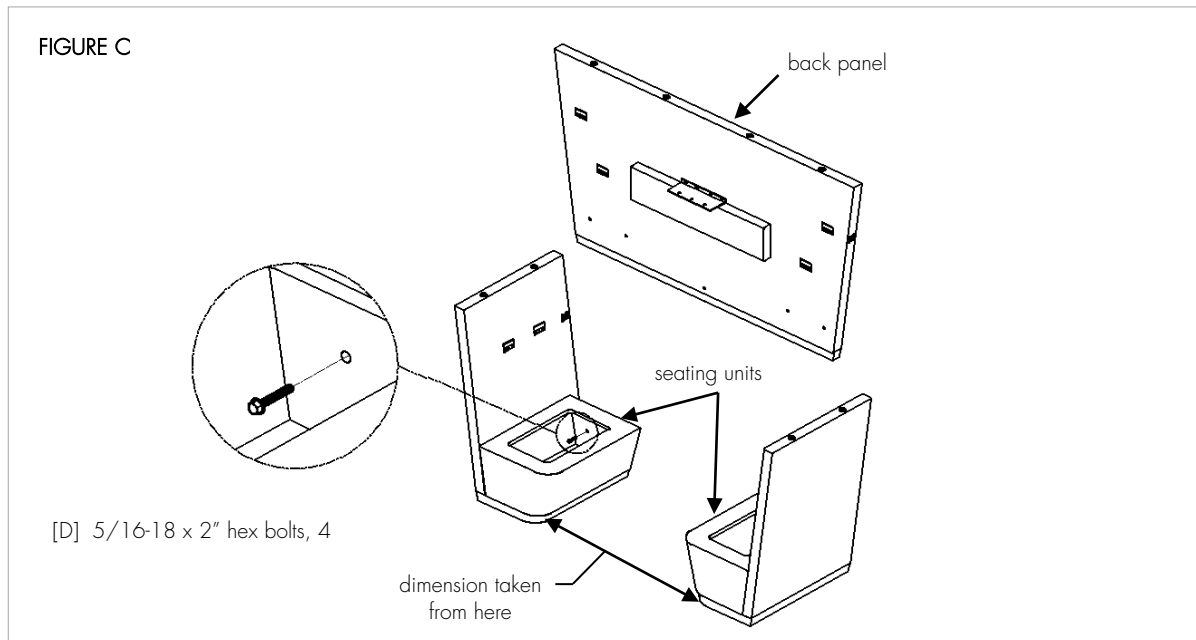

continued next page

Step 5: For veneer and laminate accent tiers only, secure the long accent tier to the small accent tiers by screwing in (6) 2" wood screws [E], three per side. Once that is complete, align the Velcro on the accent with the cover panel and secure in place (Figure E).

Step 6: Assemble the canopy next. Insert the attachment pins from the center canopy component into the curved portion of the canopy bushings. Using a 3/16 Allen key, secure together through the top using (4) 1/4-20 x .75" decorative screws [B], two per side (Figure F).

Step 7: Once the canopy is assembled, affix it to the rest of the unit by inserting the canopy attachment pins to the accent tier bushings. Gently push down until canopy is flat against the accent tiers (Figure G).

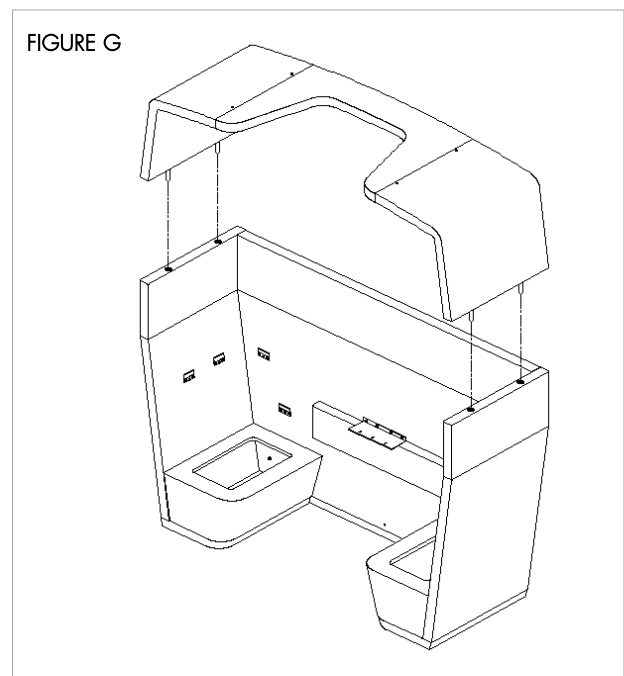
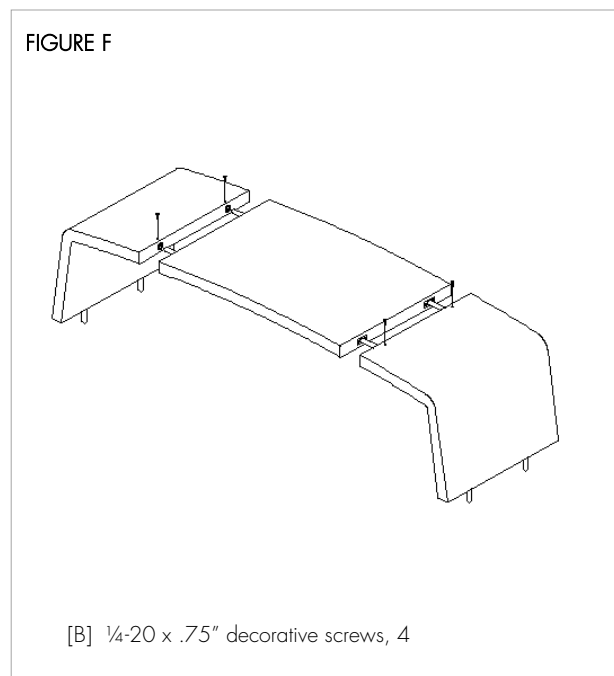
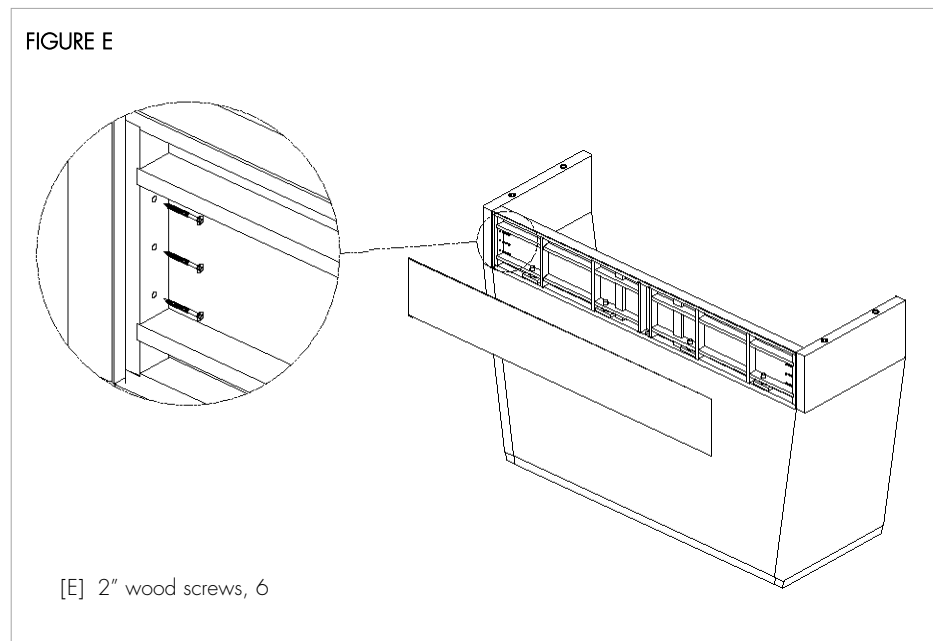

continued next page

- Step 8: Securing the unit using anchor bolts or sandbags is optional. Skip to Step 9 if neither is being utilized. Make sure the accent tiers are perpendicular to the floor before starting. First, drill the floor using the predrilled holes as guides. Affix (4) 3/8 x 5" anchor bolts [F], two per seating unit (Figure H). If using sandbags, simply place them inside the seating units, two bags per side.
- Step 9: To install the seats, tilt the seat slightly upward making sure the 1/4-20 machine screws underneath the seat cushion slide into the notches. Push the seat cushion down until it is flat against the seating unit (Figure I).
- Step 10: To install the backs, align the four z-brackets on the back rest with the four z-brackets on the seating units and gently push down until the back is flat on the top of the seat (Figure J).

FIGURE H

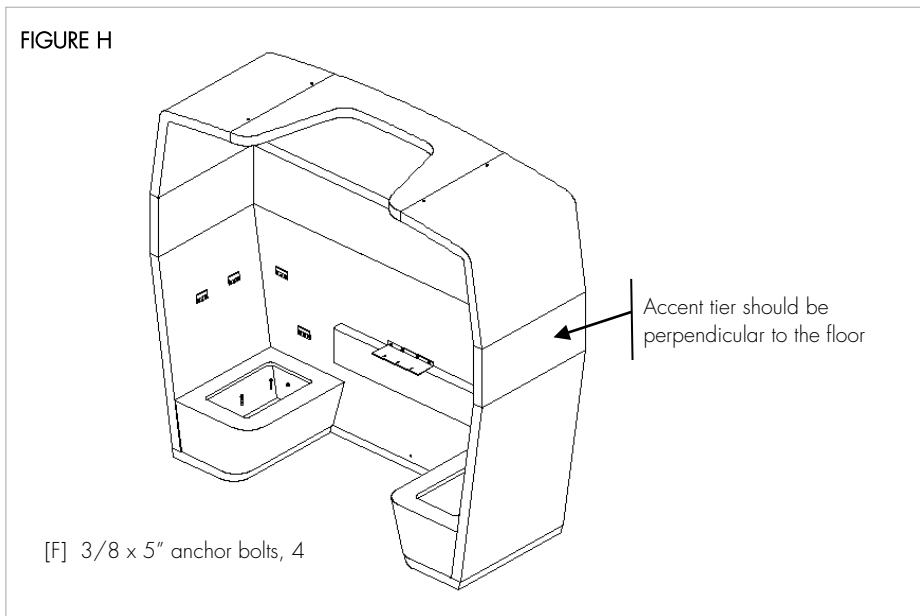

FIGURE I

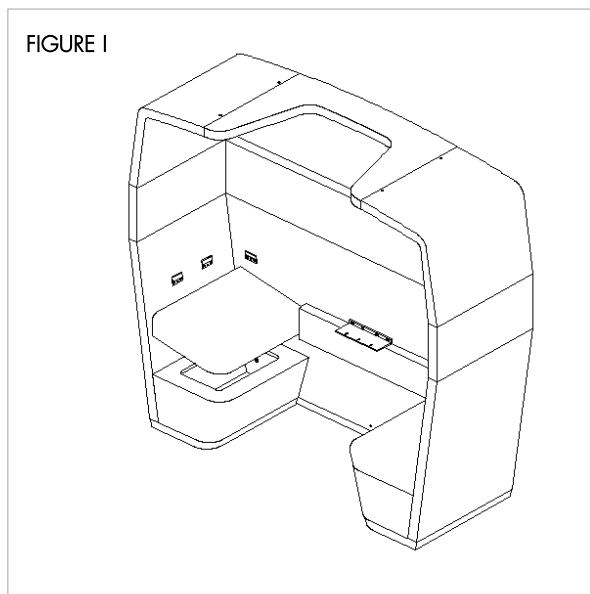
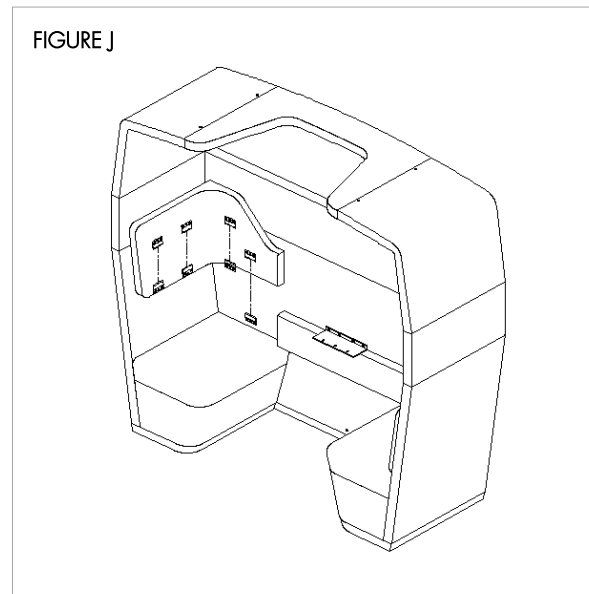

FIGURE J



continued next page

Step 11: To attach the table top, secure the table base to the unit by affixing the 5/16-18 x 1.5" hex bolts [C] to the bottom of the back panel (Figure K).

Step 12: Once the table base is secured, place the table on top of the base and L-bracket. Align the holes to the pre-inserted t-nuts and secure using the (7) 1/4-20 x 1" hex bolts [A] (Figure H).

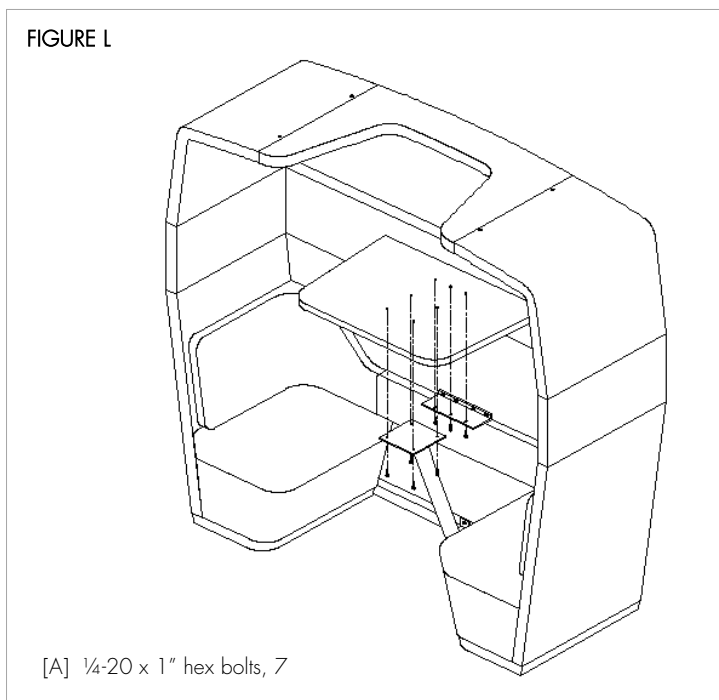
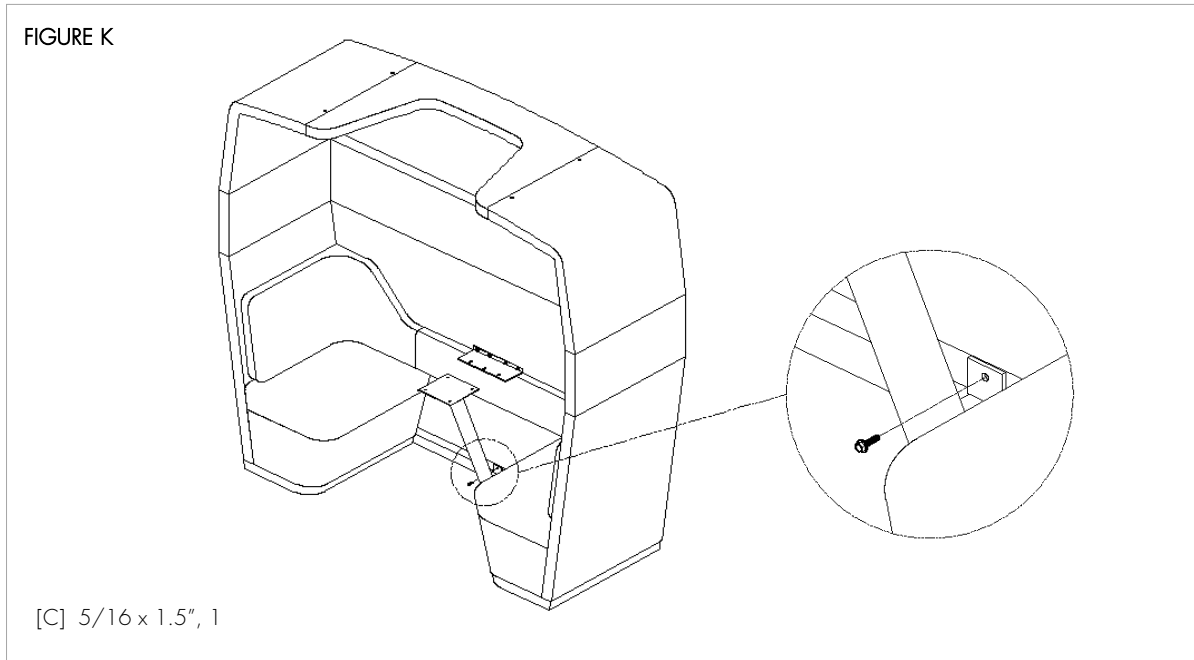

If you require additional assistance, please contact Arcadia Client Services at 800.585.5957.