

CO-OP ASSEMBLY INSTRUCTIONS – MODEL 6523 & 6523-65TL

Hardware Included:

- [A] 5/16-18 x 2" hex bolt (18)
- [B] Washer (18)
- [C] 1/4-20 x .75" decorative screw (4)
- [D] 1/4-20 x 2" hex bolt (4)
- [E] 2" wood screws (8)

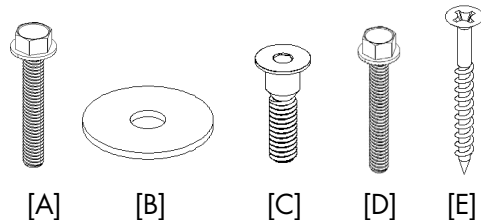

IMPORTANT – HARDWARE IS SPECIFIC FOR THE ASSEMBLY OF EACH COMPONENT. MAKE SURE THE CORRECT ITEMS ARE USED AS DIRECTED AND IDENTIFIED BELOW.

Step 1: Place the seating unit on top of the plinth base and properly secure using (6) 5/16-18 x 2" hex bolts [A], though the inside of the seating unit, into pre-inserted t-nuts (Figure A).

Step 2: Attach the back panel to the seat by placing it on top of the plinth base and properly securing with (8) 5/16-18 x 2" hex bolts [A] and washers [B], into the pre-inserted t-nuts (Figure B).

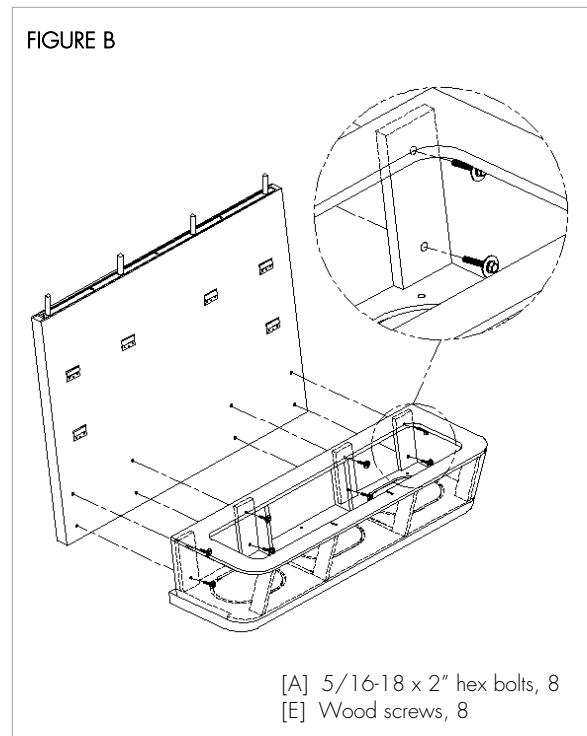
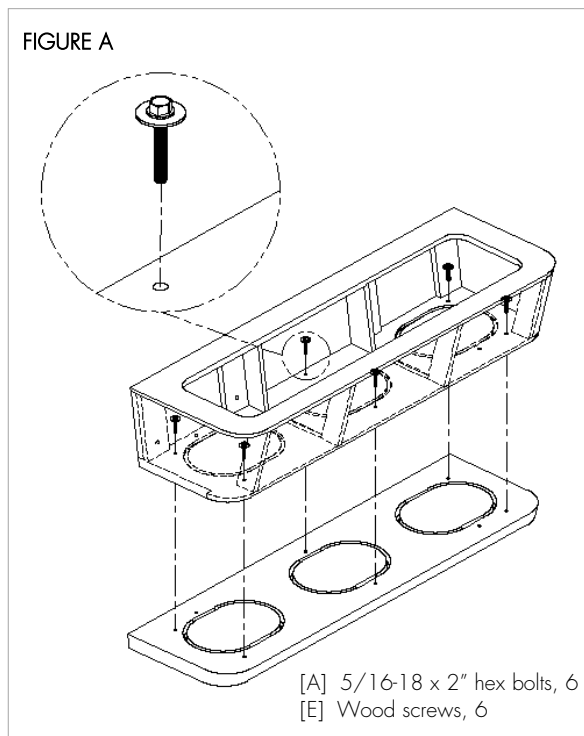

continued next page

Step 3: Once the two seating units are built, face them approximately 41.5" away from each other (measurement is taken from bottom front of both plinths). Place the front panel in-between the two seating units and secure the bottom using (4) 5/16-18 x 2" Hex bolts [A], two per seat, from inside the seat. Also, secure the top portion of the front panel by screwing in (2) wood screws [E] through the metal L-bracket, one per side (Figure C).

Step 4: Align the small accent tier attachment pins to the top of the seating unit bushings and gently push down to secure. Repeat the same process to install the long accent tier (Figure D).

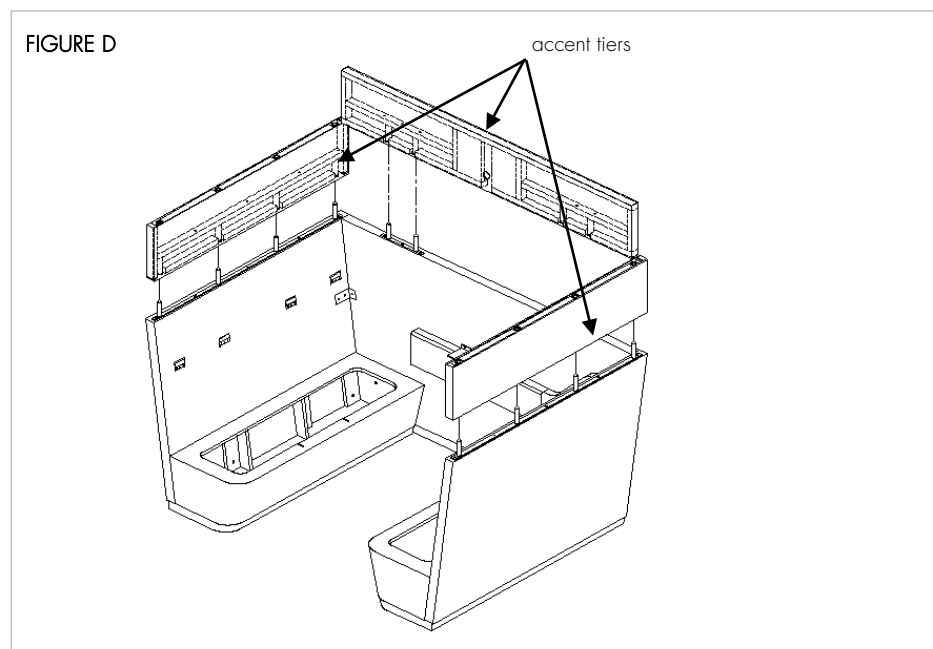
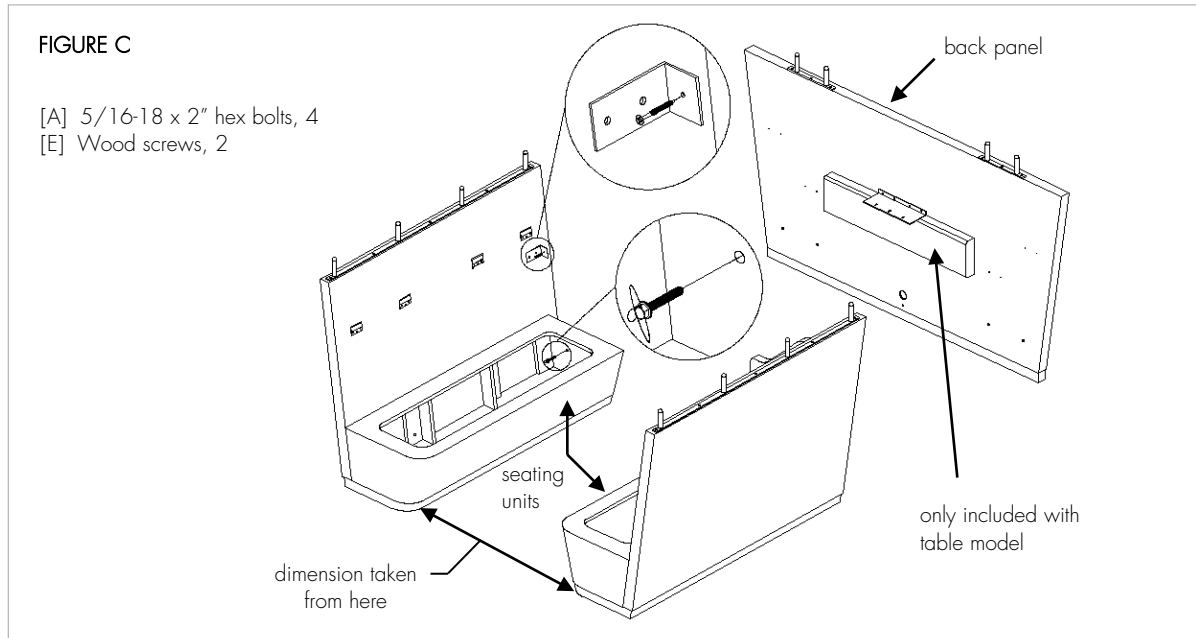

continued next page

Step 5: For veneer and laminate accent tiers only, secure the long accent tier to the small accent tiers by screwing in (6) 2" wood screws [E], three per side. Once that is complete, align the Velcro on the accent with the cover panel and secure in place (Figure E).

Step 6: Assemble the canopy next. Insert the attachment pins from the canopy elbows into the top canopy center piece bushings. Using a 3/16 Allen key, secure together through the top using (8) 1/4-20 x .75" decorative screws [B], four per side (Figure F).

Step 7: Once the canopy is assembled, affix it to the rest of the unit by inserting the canopy attachment pins to the accent tier bushings. Gently push down until canopy is flat against the accent tiers (Figure G).

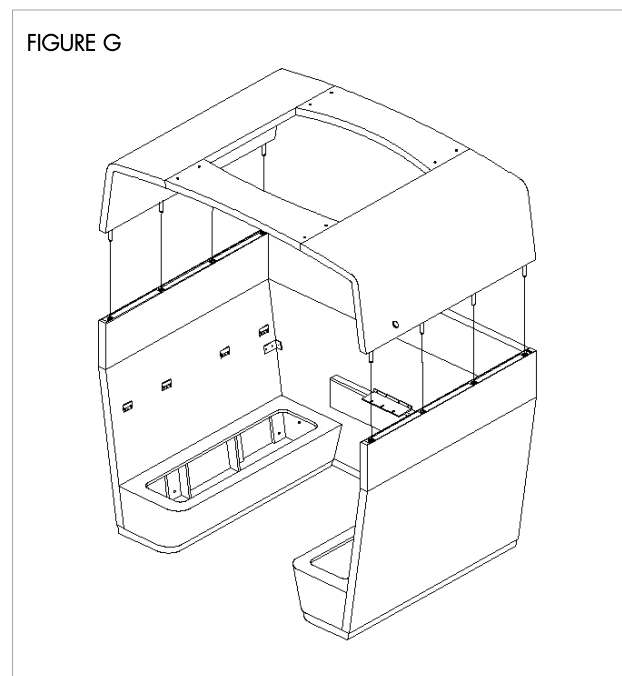
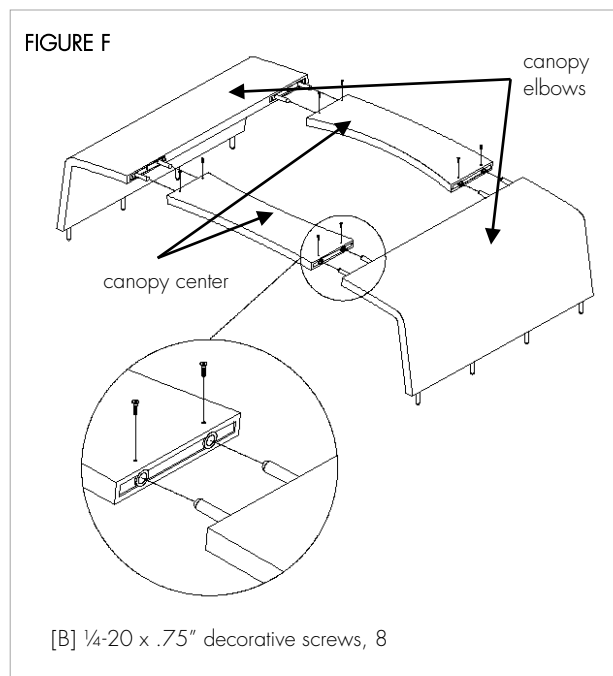
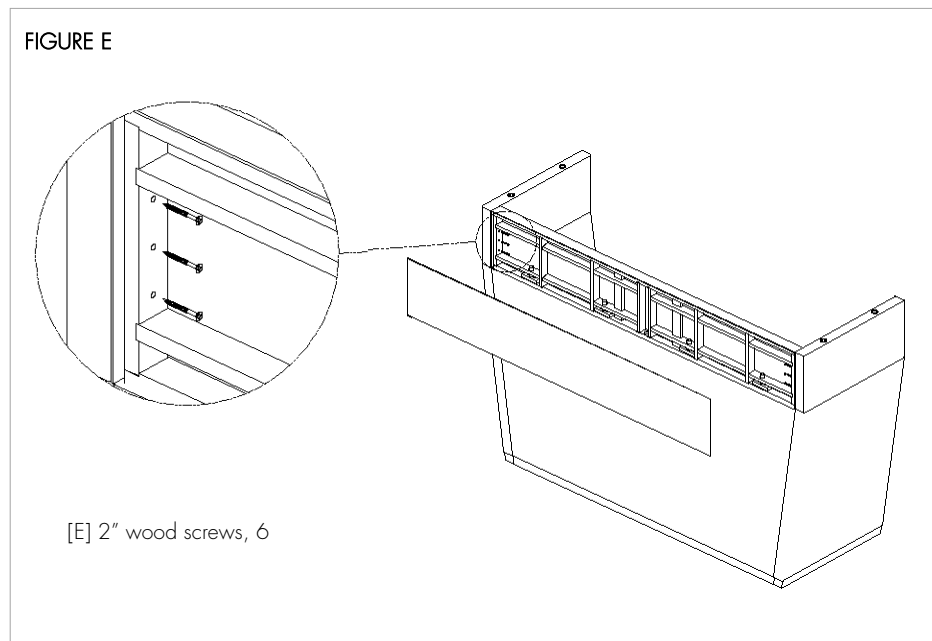

continued next page

- Step 8: To install the seats, tilt the seat slightly upward making sure the 1/4-20 machine screws underneath the seat cushion slide into the notches. Push the seat cushion down until it is flat against the seating unit (Figure H).
- Step 9: To install the backs, align the four z-brackets on the back rest with the four z-brackets on the seating units and gently push down until the back is flat on the top of the seat (Figure I).
- Step 10: To attach the table top, first place the base approximately 34.5" from the base plate to the bottom of the plinth. Place the table on top of the base and L-bracket and align the holes to the pre-inserted threaded inserts. Secure with (7) 1/4-20 x 1" hex bolts [A] (Figure J)

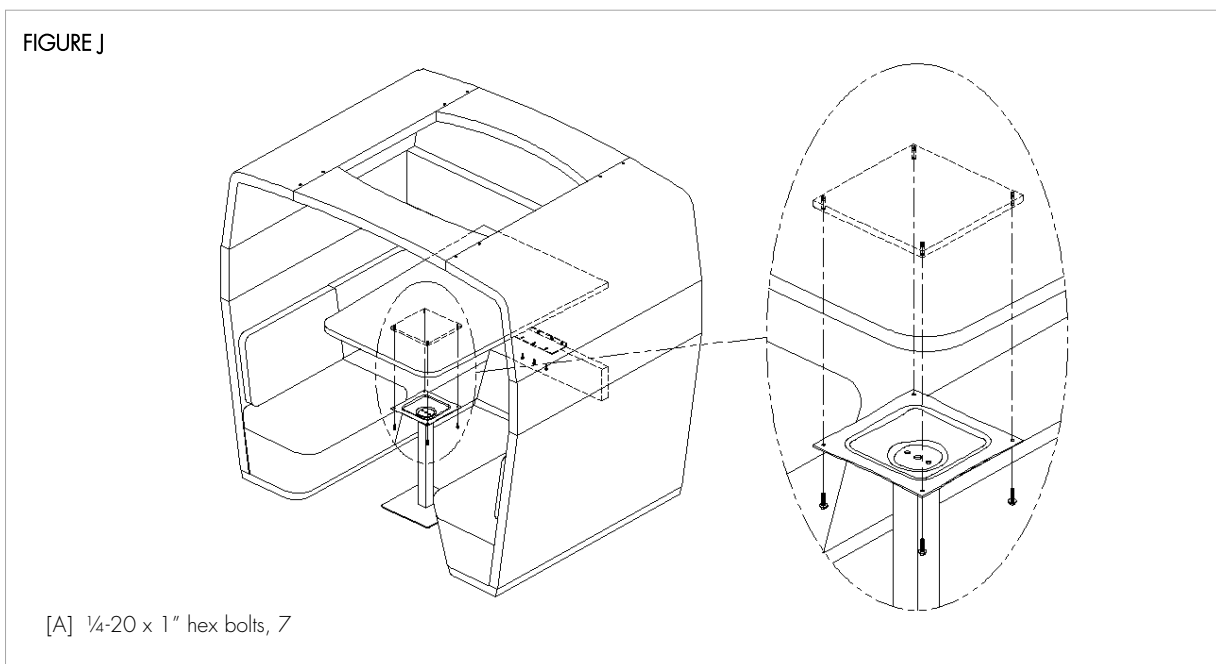
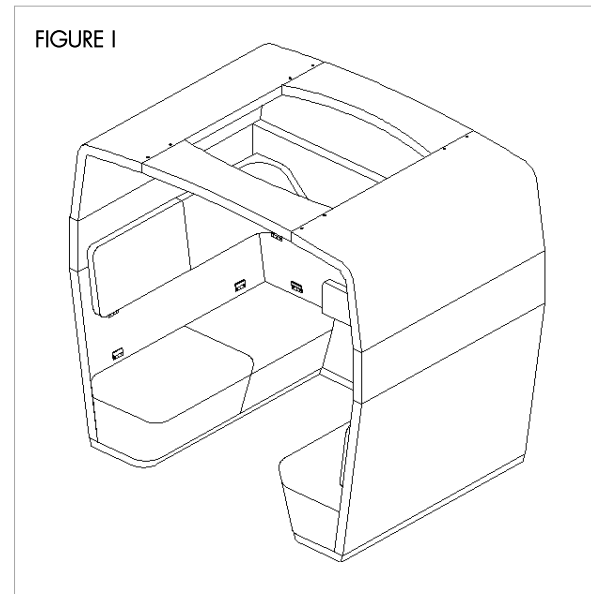
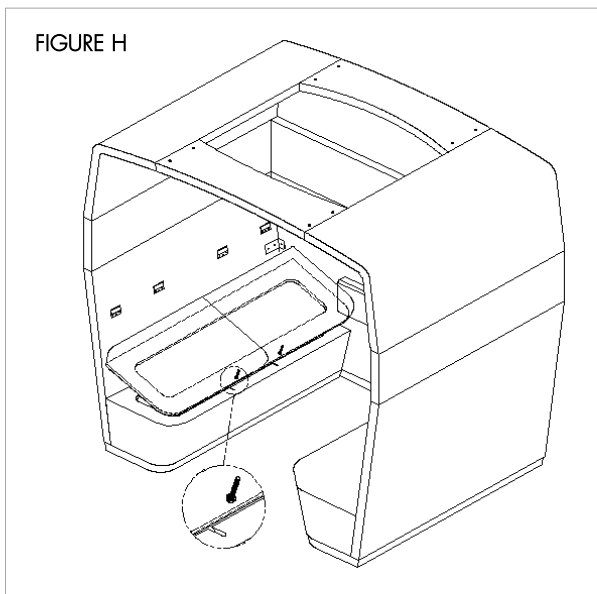

If you require additional assistance, please contact Arcadia Client Services at 800.585.5957.